

BX 453 A-90

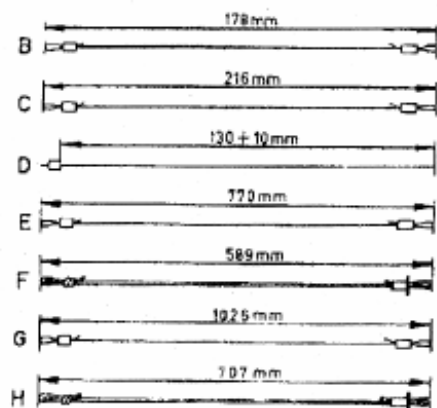

SK.F1

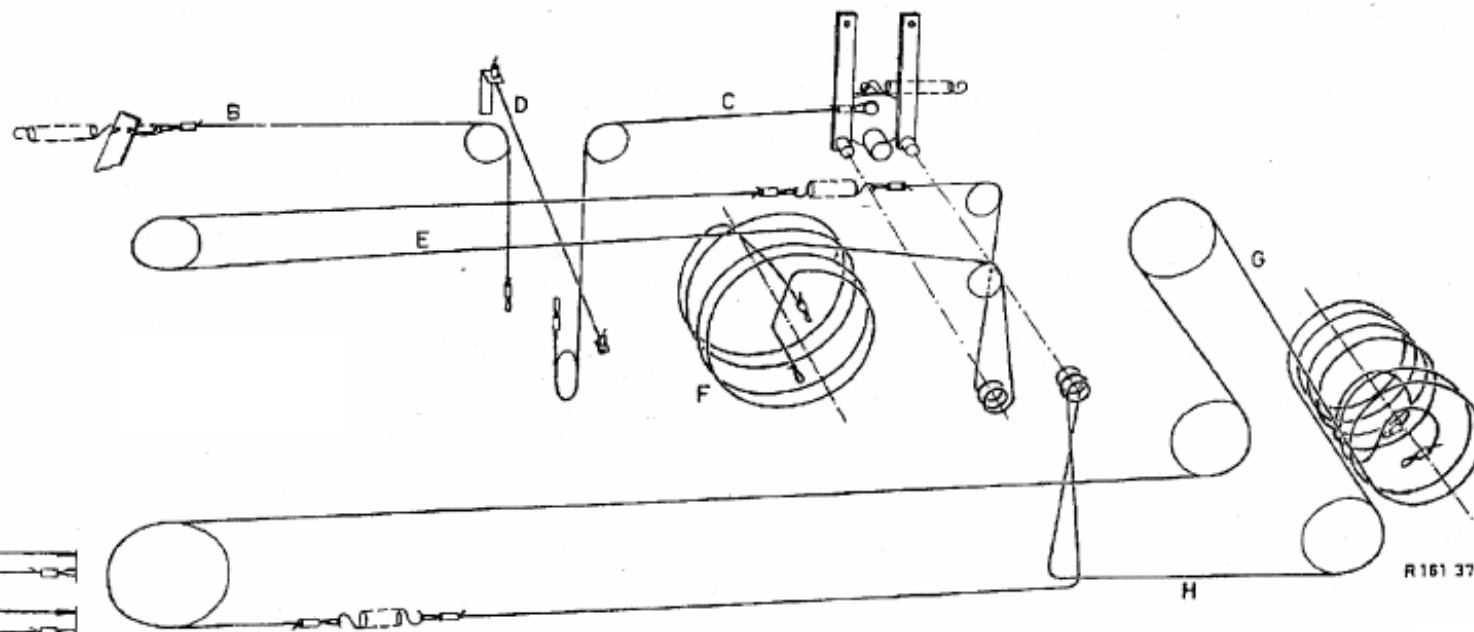

SK.F2



SK.K



SK.L



SK.2

R 161 331

Fig1